

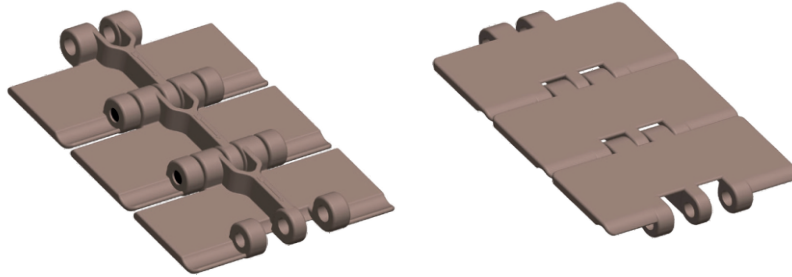

SP-820 SERIES



DIMENSION	mm	inch
P	38.1	1.50
M	42.1	1.65
L	7.20	0.28
H	13.5	0.53
E	6.35	0.25
T	4.00	0.18
O	44.5	1.73

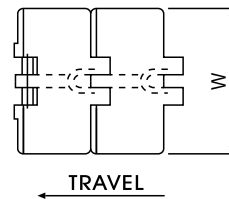
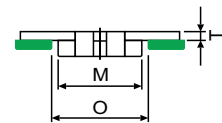
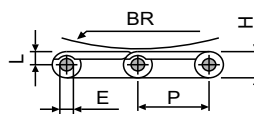

Plate Materials : polyacetal

Pin Material : Austenitic steel

standard length : 80 pitches (10 feet - 3.048 m)

SP-820 (Straight Running Plastic Chain)

	Width W (mm)	Width W (inch)	Working Load (N)	Backflex Radius(BR) (mm)	Weight (kg/m)
SP-820 K250	63.5	2.50	1230	50	0.73
SP-820 K325	82.5	3.25	1230	50	0.83
SP-820 K330	83.8	3.30	1230	50	0.85
SP-820 K350	88.9	3.50	1230	50	0.87
SP-820 K400	101.6	4.00	1230	50	0.95
SP-820 K450	114.3	4.50	1230	50	1.03
SP-820 K600	152.4	6.00	1230	50	1.25
SP-820 K750	190.5	7.50	1230	50	1.47



SP-820 SERIES ACCESSORIES

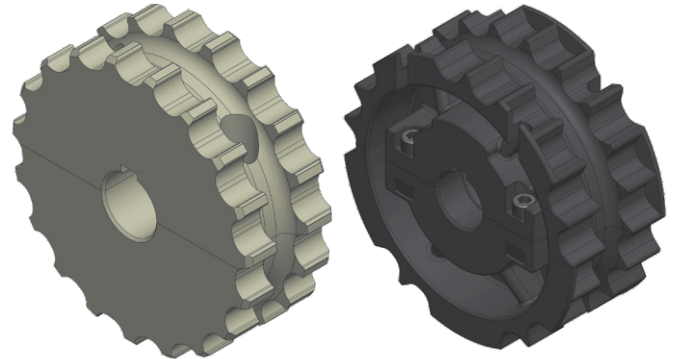
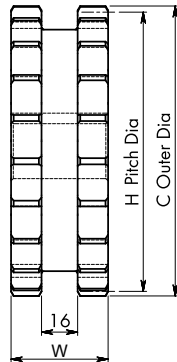
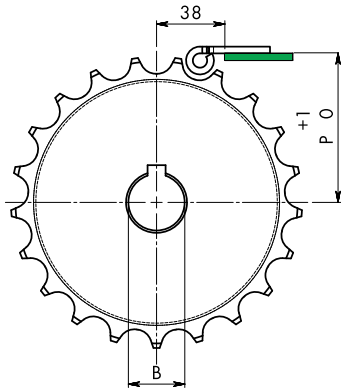

WIDTH (W)- 43 mm FOR M/C SPROCKET ,M/C SPLIT SPROCKET
AND 53 mm FOR MOULDED SPROCKET

MATERIAL : POLYAMIDE

SP-820 (SPROCKET)

CODE	TEETH (Z)	C	H	P	M/C	M/C SPLIT	MOULDED SPLIT
SP-820 S 17	17	103.9	105.47	55.9	■	■	
SP-820 S 19	19	117.0	117.34	61.9	■	■	■
SP-820 S 21	21	129.0	129.26	67.8	■	■	■
SP-820 S 23	23	142.0	141.21	73.8	■	■	
SP-820 S 25	25	154.0	153.21	79.8	■	■	■
SP-820 S 27	27	166.8	165.20	85.8	■	■	
SP-820 S 29	29	178.5	177.24	91.8	■	■	

BORE (B) - Ø 25,30,35,40

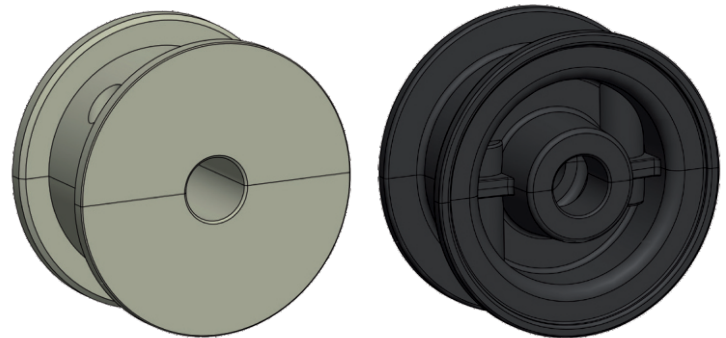
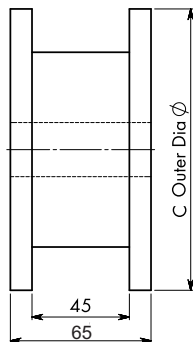
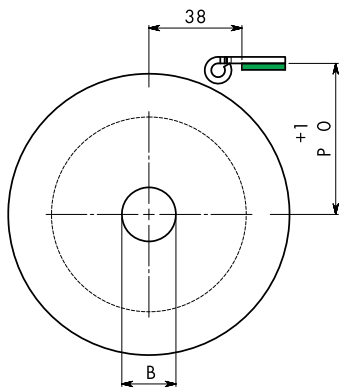

MATERIAL : POLYAMIDE

SP-820 (IDLER)

CODE	TEETH Z	C	P	M/C	M/C SPLIT	MOULDED
SP-820 I 17	17	104.0	56.2	■	■	
SP-820 I 19	19	117.0	62.6	■	■	
SP-820 I 21	21	129.8	68.6	■	■	■
SP-820 I 23	23	142.2	74.6	■	■	
SP-820 I 25	25	154.7	80.5	■	■	■
SP-820 I 27	27	167.2	86.5	■	■	
SP-820 I 29	29	179.3	92.8	■	■	

BORE (B) - Ø 25,30,35,40



SP-820 SERIES ACCESSORIES

CHAIN POSITIONING FOR SINGLE ROW

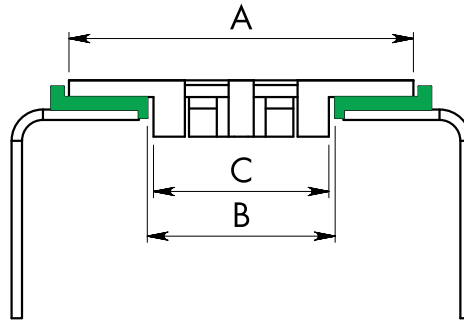

CHAIN POSITIONING FOR MULTIPLE ROW

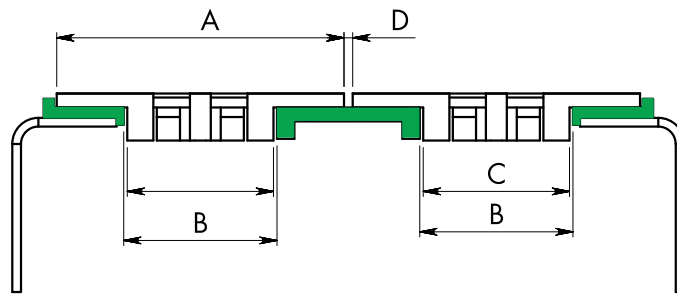

SP-820 (CHAIN POSITION)

CHAIN CODE	A	B	C	D
SP-820 K250	63.5	44.5	42.1	2.5
SP-820 K325	82.5	44.5	42.1	2.5
SP-820 K330	83.8	44.5	42.1	2.5
SP-820 K350	88.9	44.5	42.1	2.5
SP-820 K400	101.6	44.5	42.1	2.5
SP-820 K450	114.3	44.5	42.1	2.5
SP-820 K600	152.4	44.5	42.1	2.5
SP-820 K750	190.5	44.5	42.1	2.5